

Specification

General	product name	SA130
	dimensions	164*102*138.3 mm
	weight	2 kg
	supported aircraft	SOUTH SF1200/SF3300/SF4200 Matrice 300 RTK/350 RTK
	working temperature	-20°C~+55°C
System Performance	IP	IP64
	system accuracy	5 cm@300 m (Horizontal/Vertical)
	storage	256 G Flash Drive Disk
	control mode	auto control by Ground control station or remote control by Laptop/ Mobile phone APP
LiDAR	laser scanner	400 scan-line
	principle	pulse
	maximum measuring range	1500 m
	minimum detection range	1 m
	measuring accuracy	15 mm(single)/ 5 mm(repeat)
	measurement rate	max.2000,000 points/s
	scanning FOV	100°
	laser safety class	Class 1 (IEC 60825-1: 2014) eye-safe
	angular resolution	0.001°
	laser wavelength	1550 nm
	echo	multi-echo
	Inertial Navigation System	posture
positioning accuracy		horizontal: 0.01 m; vertical: 0.02 m
IMU Update Frequency		500 Hz
RGB Mapping Camera	resolution	45 MP
	focal length	18 mm
	sensor size	36*24 mm(8192*5460)
	pixel size	4.4 μm
	photo format	JPEG
	video format	MP4
Data collection software(GCS)	Fly2MAP Pilot	
Trajectory processing software	AcuteLas Studio software	
LiDAR data post-processing software	AcuteLas Studio software	

High-Precision Aerial LiDAR System

SA130

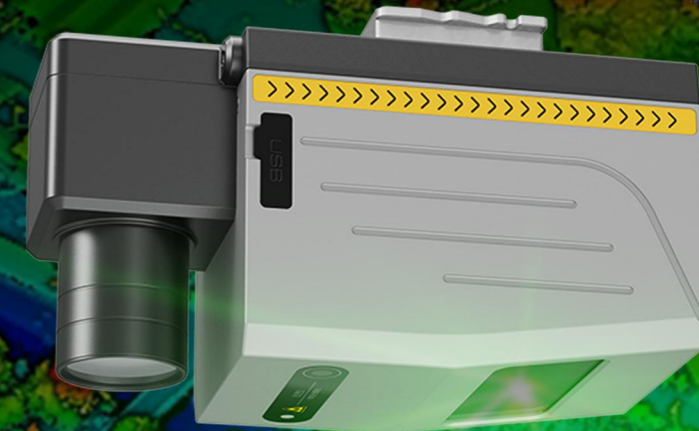

SOUTH
Target your success

SOUTH SURVEYING & MAPPING TECHNOLOGY CO., LTD.

Telephone- 011-49995999 , Mobile- +91-9999999255
Location: 1111, 11th Floor, RG Trade Tower Plot No. B-7, Netaji Subhash Place Pitampura
New Delhi -110034
Email: india@southprecision.in

SOUTH
Target your success

● System accuracy achieves
5 cm@ 300 m

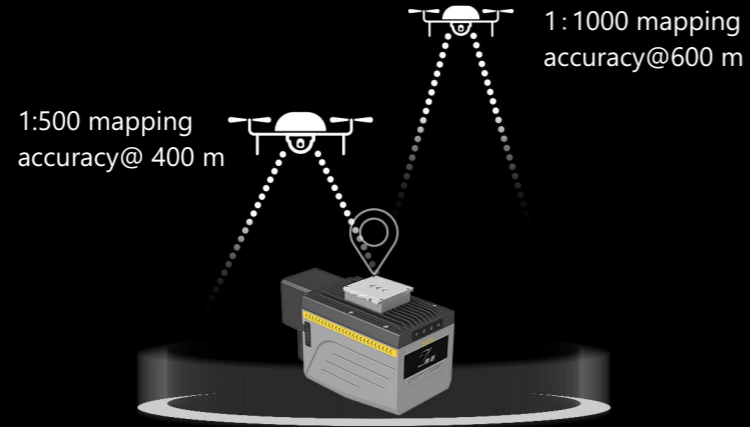

● Multi-echo penetrates the vegetation
and acquires the real terrain type

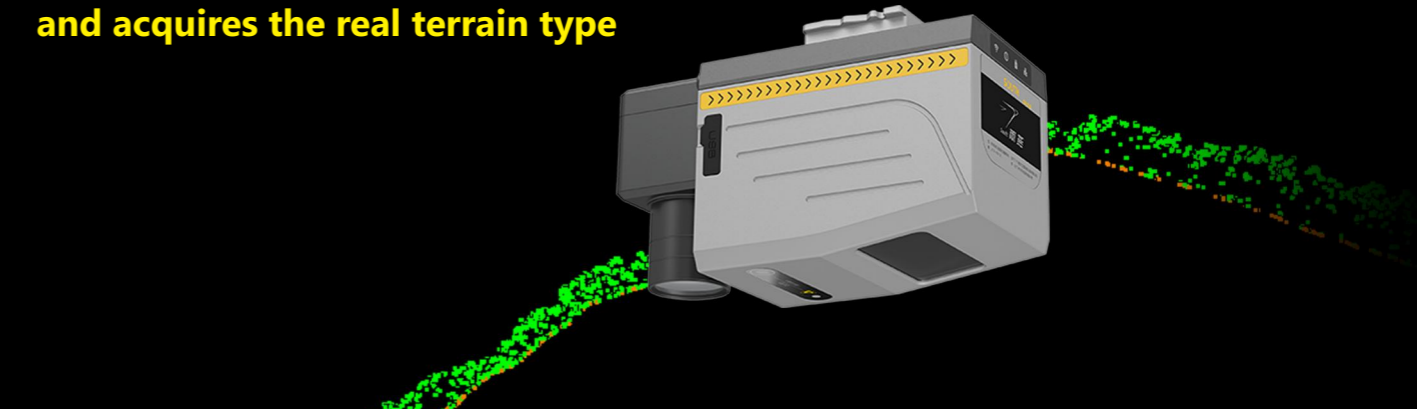

● Measuring range
maximum reaches
up to 1500 m

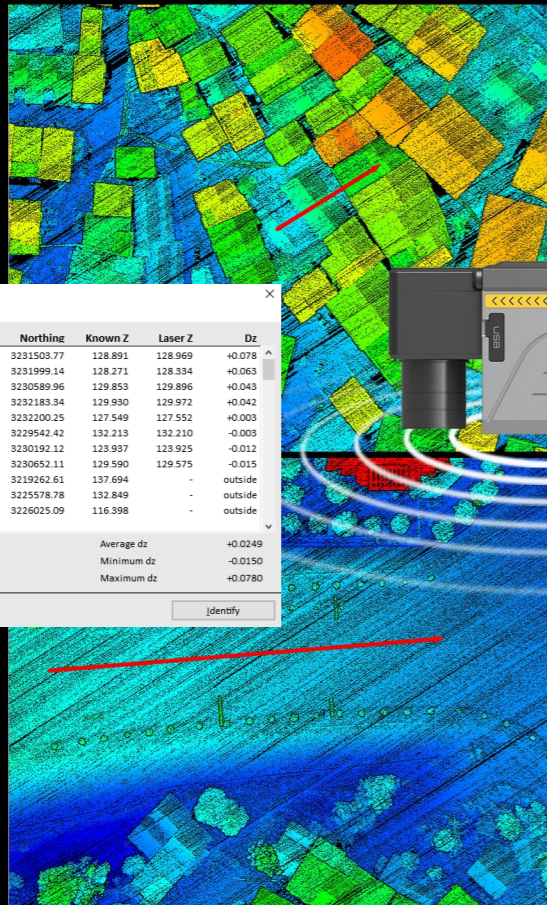

flight trips mosaic result@300 m

Control report - F:\TXX\KXD-84.txt

Use	Number	Easting	Northing	Known Z	Laser Z	Dz
<input checked="" type="checkbox"/>	XX21	584797.19	3231503.77	128.891	128.969	+0.078
<input checked="" type="checkbox"/>	XX24	587281.86	3231999.14	128.271	128.334	+0.063
<input checked="" type="checkbox"/>	XX19	583470.66	3230589.96	129.853	129.896	+0.043
<input checked="" type="checkbox"/>	XX23	586475.61	3232183.34	129.930	129.972	+0.042
<input checked="" type="checkbox"/>	XX22	585415.74	3232200.25	127.549	127.552	+0.003
<input checked="" type="checkbox"/>	XX17	582786.23	3229542.42	132.213	132.210	-0.003
<input checked="" type="checkbox"/>	XX18	582884.95	3230192.12	128.937	128.925	-0.012
<input checked="" type="checkbox"/>	XX20	584098.20	3230652.11	129.590	129.575	-0.015
<input type="checkbox"/>	XX1	574626.83	3219262.61	137.694	-	outside
<input type="checkbox"/>	XX10	578752.70	3225578.78	132.849	-	outside
<input type="checkbox"/>	XX11	579003.56	3226025.09	116.398	-	outside
Average magnitude		0.0324		Average dz		+0.0249
Std deviation		0.0361		Minimum dz		-0.0150
Root mean square		0.0419		Maximum dz		+0.0780

Show location Identify

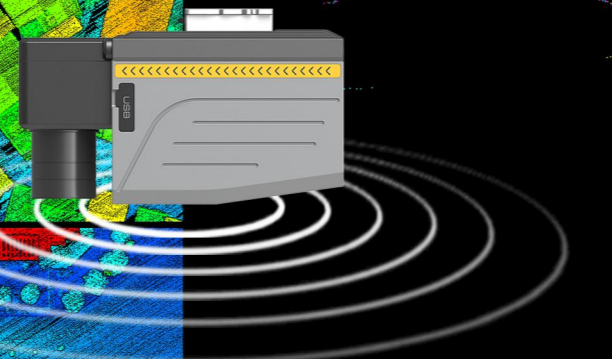

ground point cloud thickness
reaches 5 cm on hard
surface@300 m

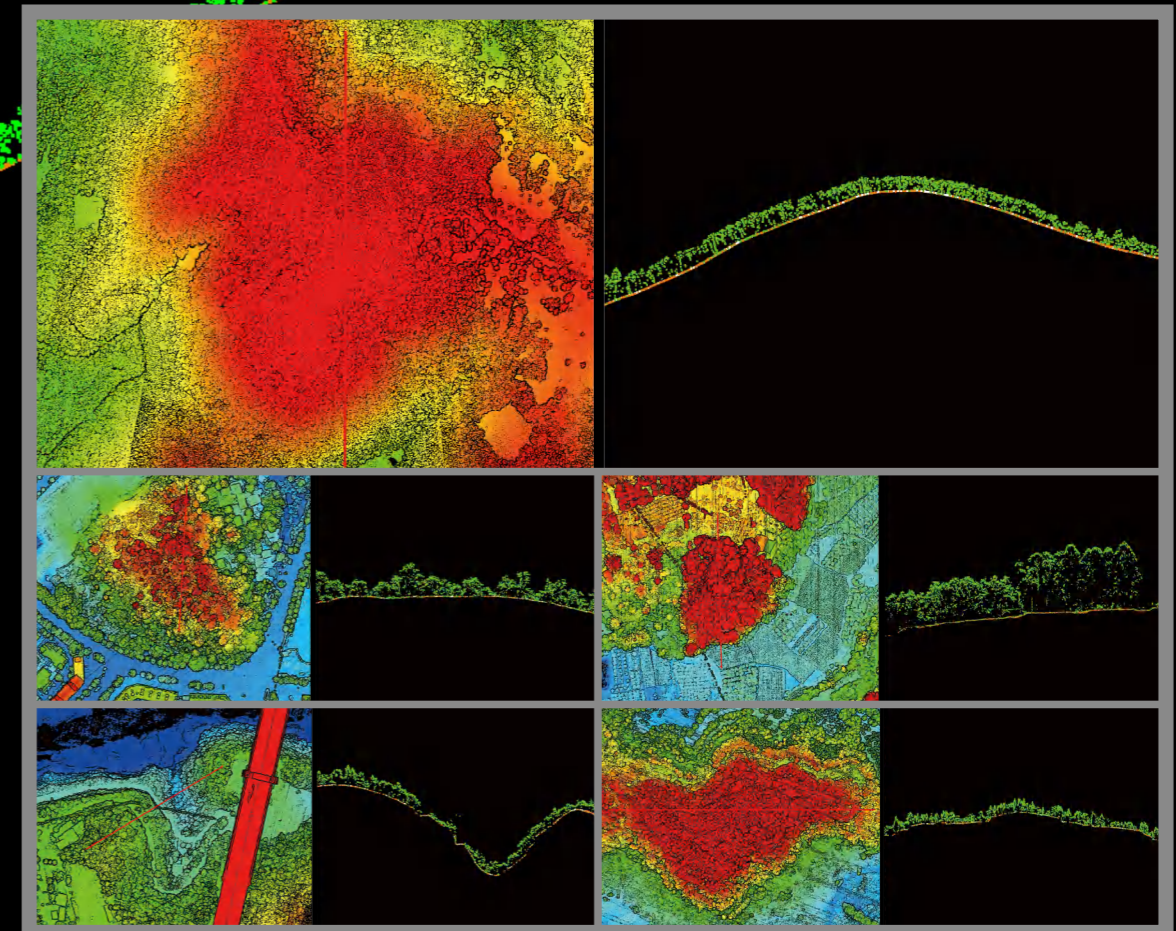

● Platforms



SOUTH fixed wing SF4200-150 min



SOUTH Quadcopter SF1200-50 min



DJI M300/M350 RTK-about 25 min



SOUTH Fixed wing SF3300-100 min

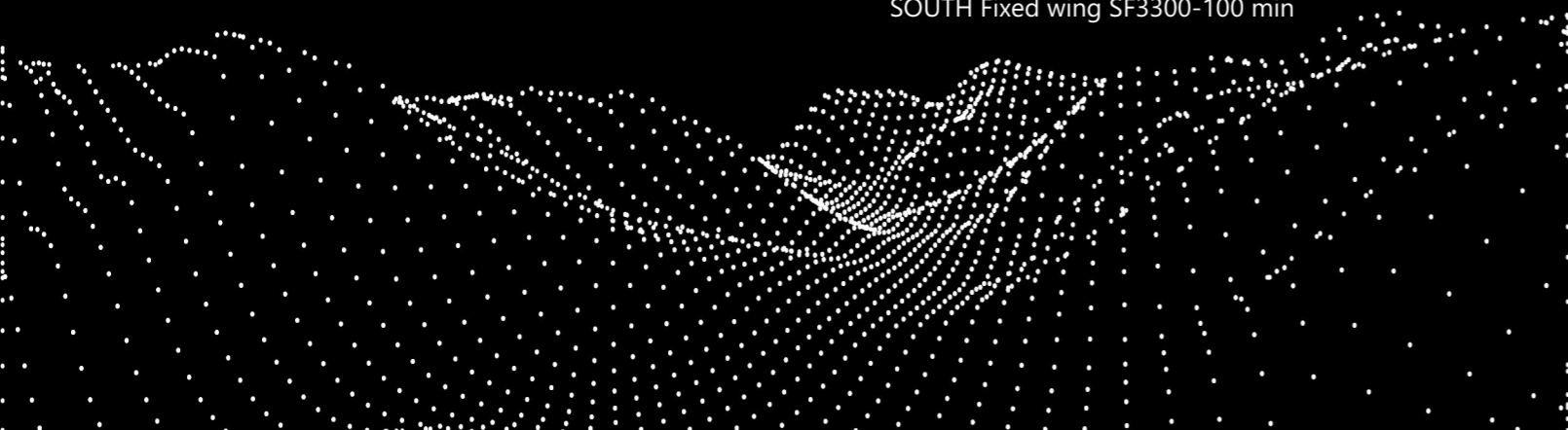

● On-stop field work control with UAV Flight Control Software Fly2Map Pilot

Highly integrated flight platform-Fly2Map Pilot is ready to set flight parameters, camera parameters and LiDAR parameters at the same time, no more laptop for LiDAR control.

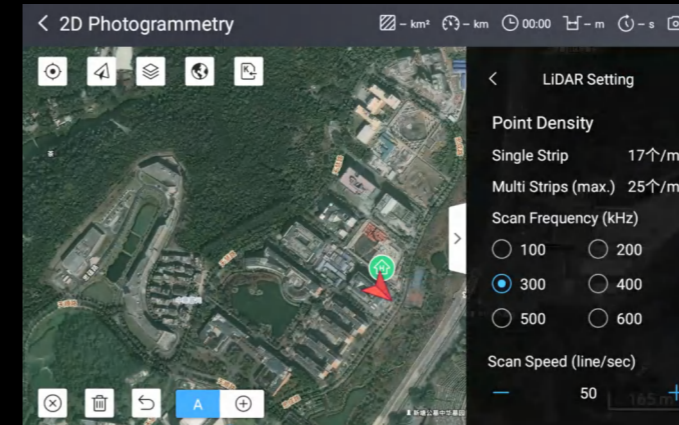

a. UAV and LiDAR setting all in one RC

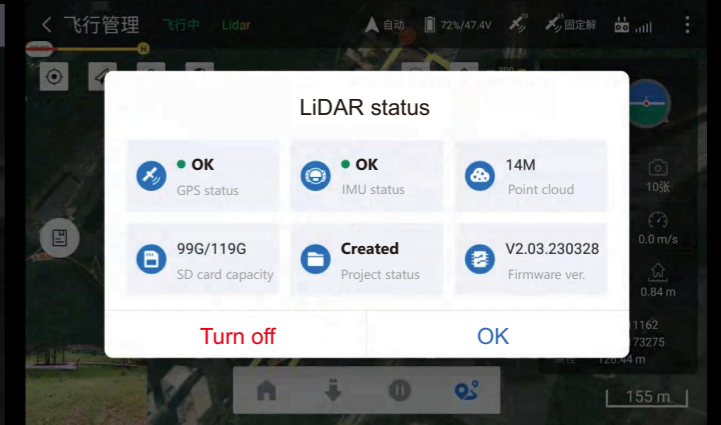

b. realtime monitor and control LiDAR status on GCS

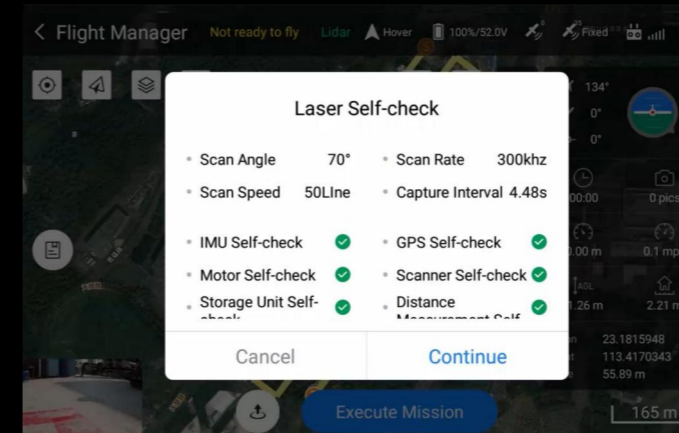

c. LiDAR self-check and IMU initializing on GCS(no need 8-shape check).

● Drone SF1200

SOUTH Quadcopter SF1200 has long induration time, obstacle avoidance, and terrain-following functions, it realizes the integrated control of drone and LiDAR, one-key to take off and don't need laptops to control or set LiDAR parameters any more before take off.

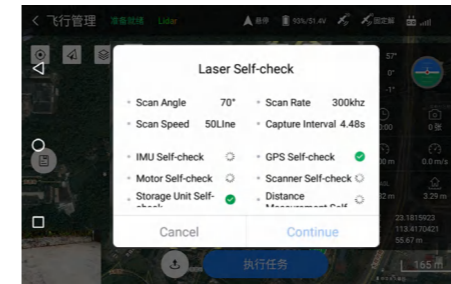
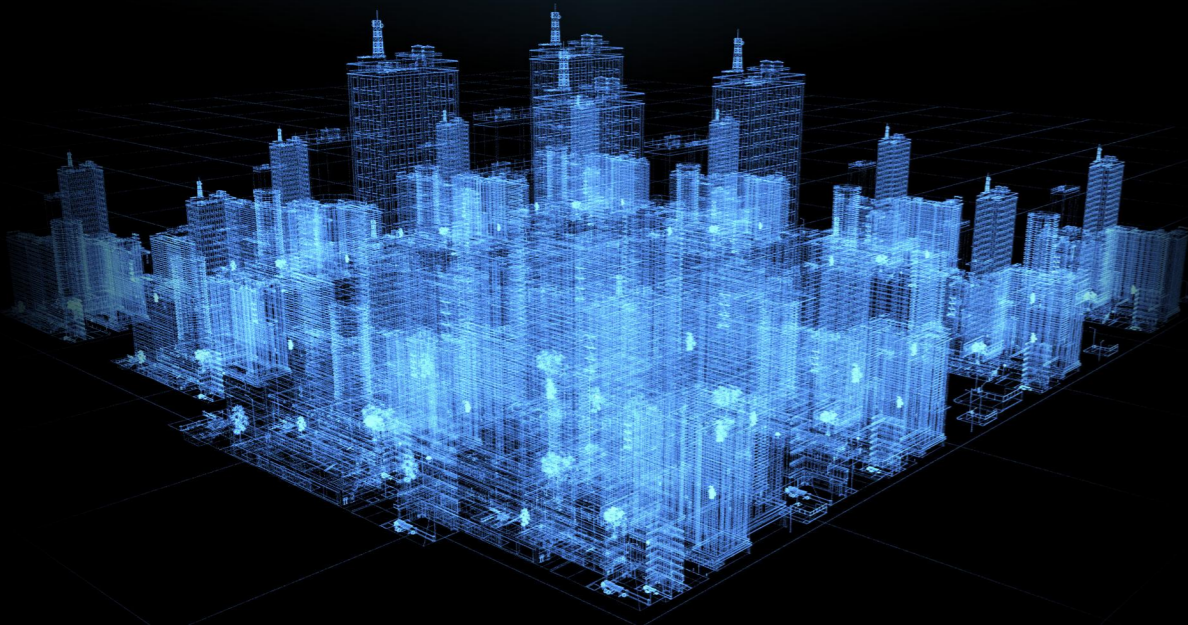

Integrated control of drone and LiDAR

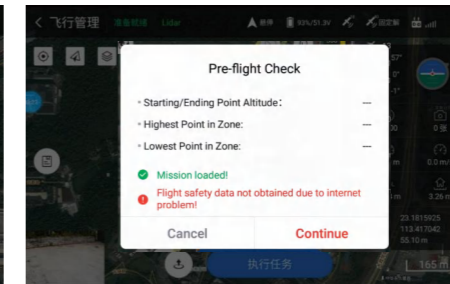

One-key to fly

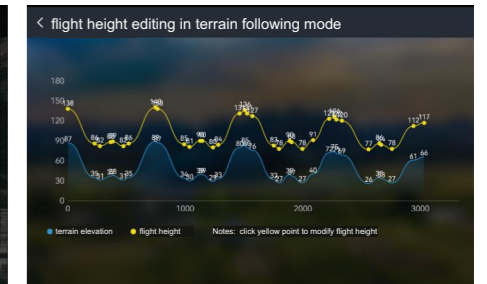

Terrain following available



Portable transport case



Wireless realtime video transmission



Smart Charging Hub

Drone SF1200 parameter

Diagonal wheelbase	1.15 m(±0.01 m)	Wind resistance	Beaufort scale 5
Dimension	Packing size: 570*520*260 mm Unfold size: 920*920*440 mm	Radio datalink range	10 km
Takeoff weight(w/o payload)	12 kg	Positioning accuracy	H: ±1 cm+1 ppm V: ±2 cm+1 ppm
Maximum payload	4 kg	Differential mode	RTK/PPK
Duration time	60 min w/o payload; 50 min with 3 kg payload	Working temperature	-20°C~+50°C
Max. climbing speed	5 m/s	Payload type	RGB camera, 5-Lens camera, LiDAR
Min. descending speed	5 m/s	Terrain following function	Available
Velocity	Max cruising 18 m/s	Obstacle avoidance	Forward 40 m, millimeter-wave radar detection
Maximum ceiling	>4500 m		

● AcuteLas Studio Software

AcuteLas Studio software is designed to process AcuteLas series aerial LiDAR system data and 3D laser scanner data, including the functions one-key trajectory processing and laser scanner/LiDAR data processing and fusion, point cloud data quality check, quality report output, coordinate system conversion, point cloud classification, topographic survey module, etc.



● One Key Processing

AcuteLas studio is capable to process terrestrial scanner data, aerial lidar data, and it can process data in batches, that means several groups data can be imported at the same time and process together.

1- import several flights data

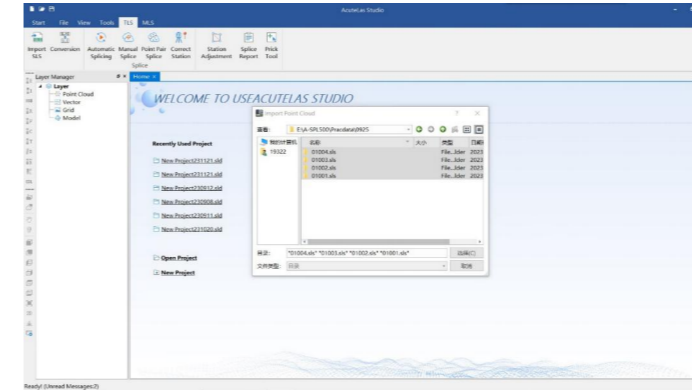

2- several flights POS data processing

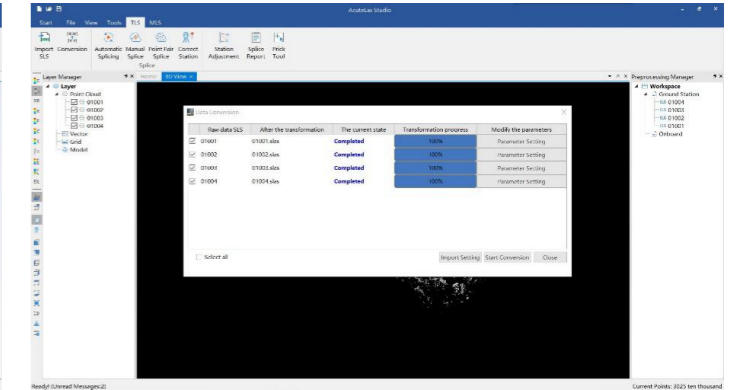

3- flight strips division

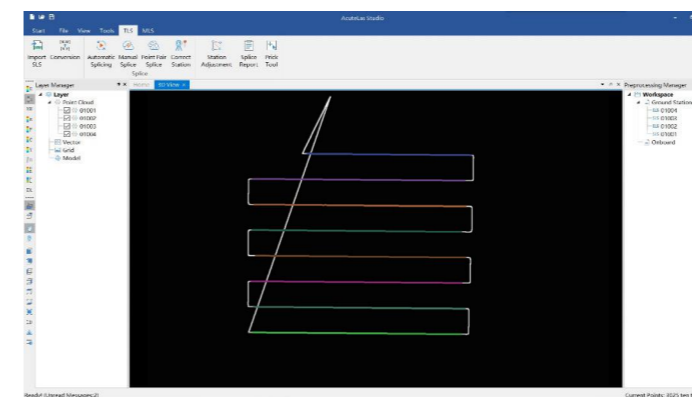

4- several flight data fusion

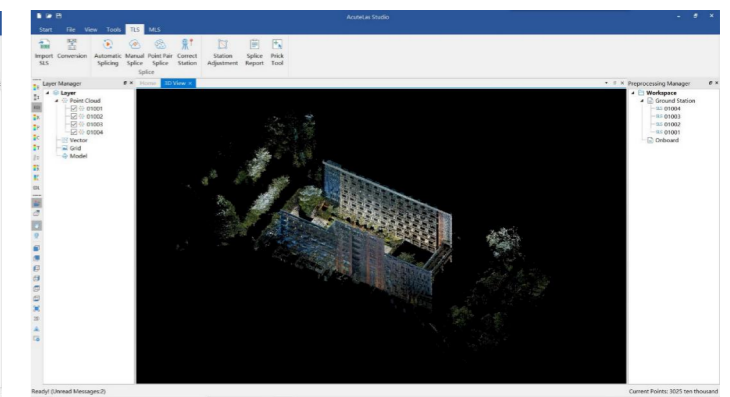

Data Pre-process

Support to process TLS data /MMS data.

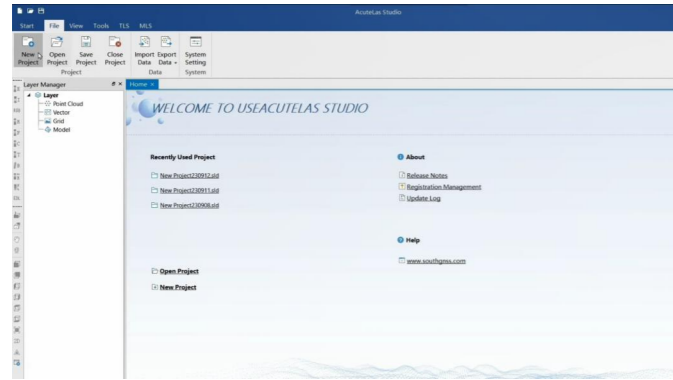

Automatically and manually Global Registration

Support to precisely register TLS data and MMS data manually or automatically.

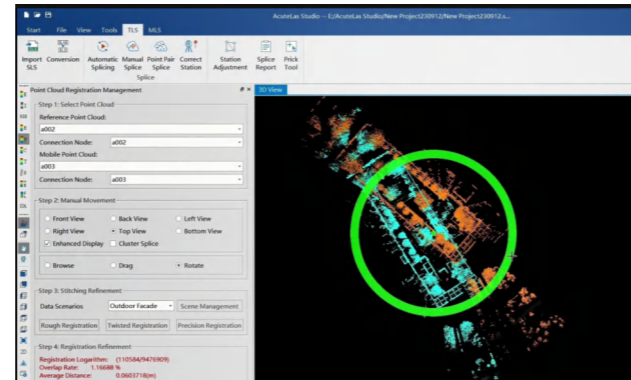

Point cloud quality verification report

Support to verify the point cloud accuracy, output verification report.

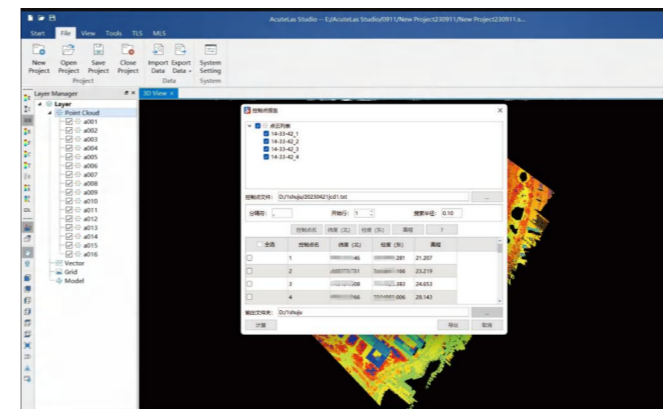

Point cloud rendering and display

Support to render the point cloud by elevation, color, intensity, class, time, etc. and display the point cloud in section view.

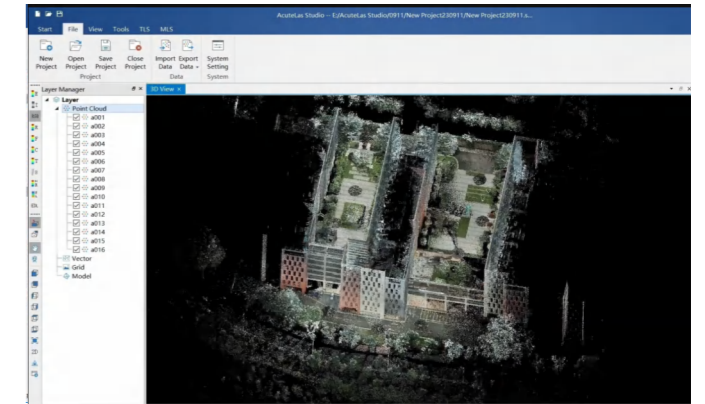

Coordinate system transformation

Support to convert coordinates with different methods.

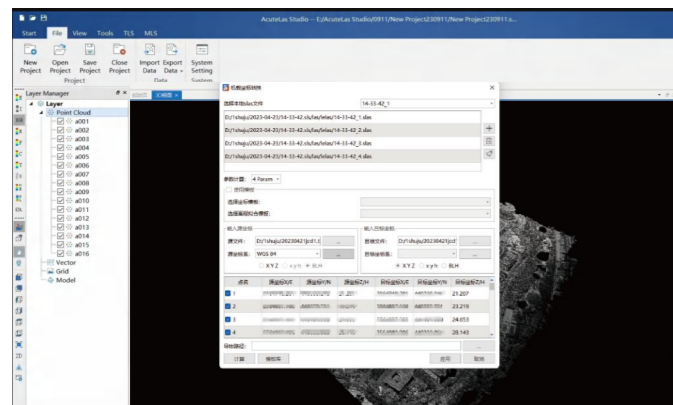

Point cloud correction

Support to adjust the trajectory and point cloud.

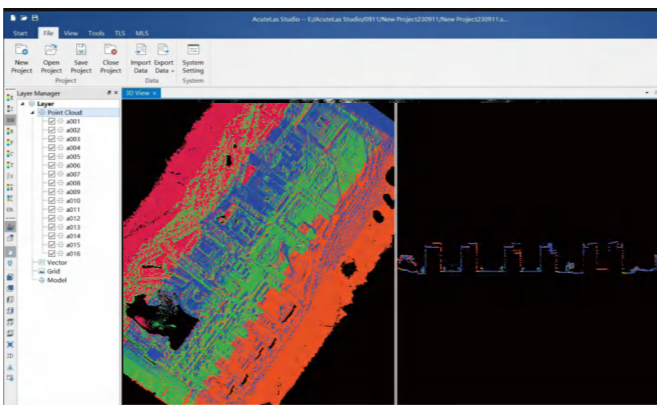

Point cloud classification

Support to classify point cloud manually or automatically.

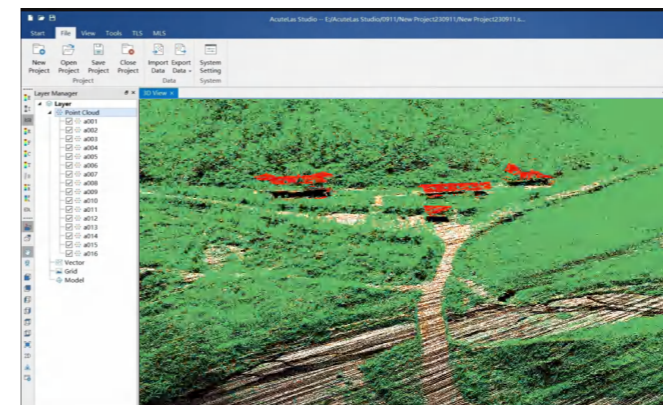

Topographic surveying module

Support to generate DEM/DSM, one key to extract contours or elevation points.

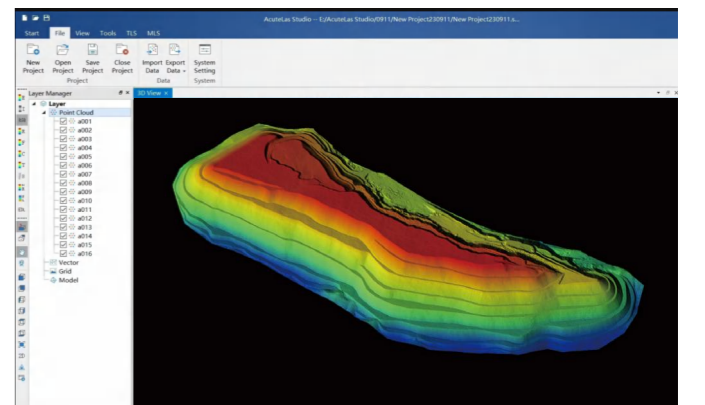

• Applications



traffics management

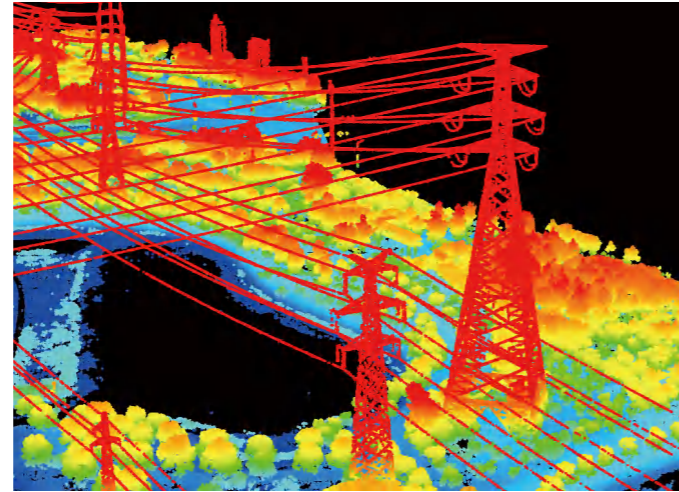

powerline inspection

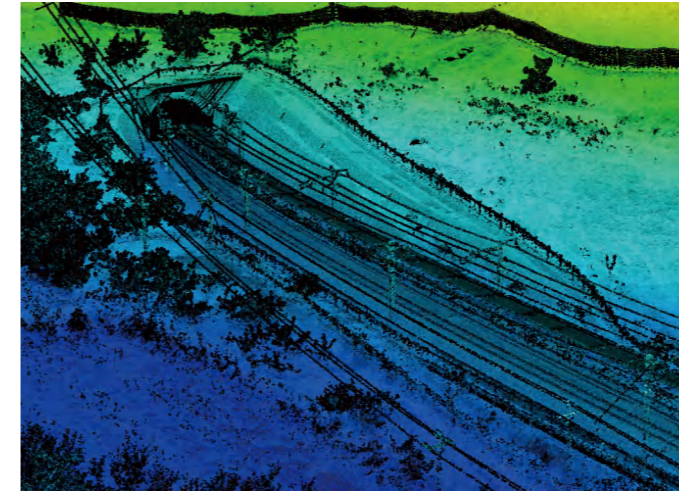

railway inspection

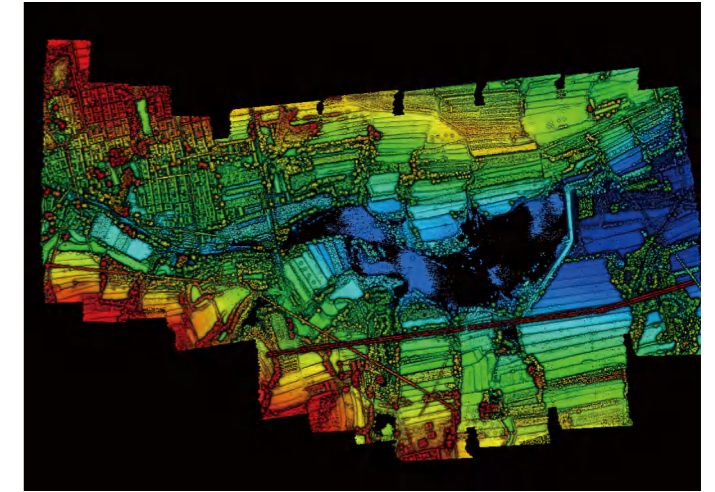

topographic surveying



city planning

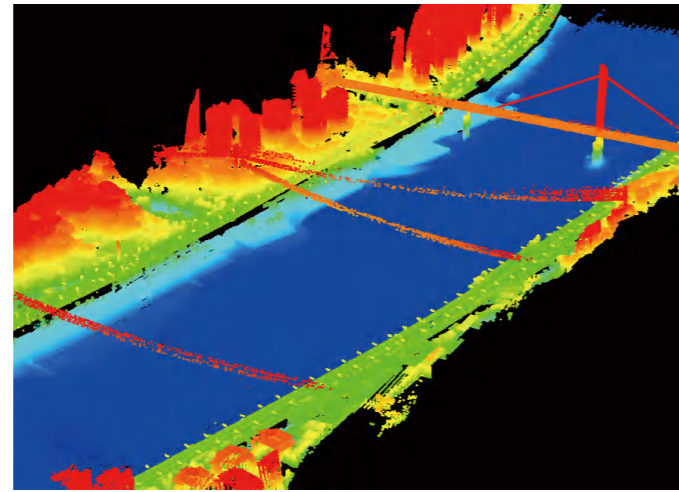

river surveying

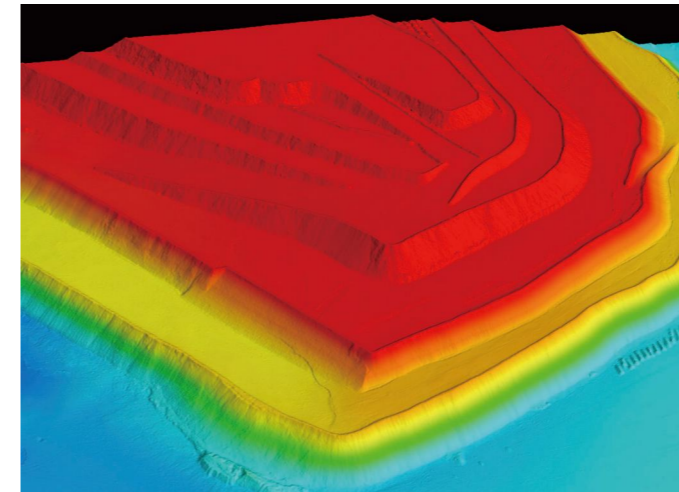

mine surveying



digital tourism